

SAFETY FIRST

Isolate the mains electrical supply before commencing installation.

All electrical work must be carried out by suitably qualified engineers in accordance with the latest IEEE regulations.

TOOLS REQUIRED

Tri-head key	Philips screwdriver
5mm AF Allen key	Small spade electrical screwdriver
13mm Ring open ended spanner	Wire strippers

FITTING PROCEDURE

1. Open the Pulsa unit by unscrewing the two Tri-head screws on the back of the unit.
2. You may find the following operations easier by removing the Vari-fix back door from the PULSA. This is done by removing the service plate (Fig2) from the back door, then remove and retain the two countersunk hinge mounting screws using a 5mm AF Allen key.
3. Assuming that the mounting post has already been drilled, deburred and surface protected, feed the supply cable through the supply post and into the back of the Vari-fix back door through the cable entry gland (Fig1).
4. Ensure that the cable entry gland is tightened onto the incoming supply cable. The gland is fitted with a standard insert to accommodate cable sizes 9-14mm. An extra insert to accommodate cable sizes 13-18mm is included in a grip seal bag in the body of the Pulsa.
5. Select the appropriate Vari-fix post fixing kit for the mounting post diameter and remove the M8 form C washers and M8 Full nuts (Fig1).
6. With the back door located in line with the post cable hole, offer one of the U-Bolts around the mounting post and penetrate the two projecting Rotaplugs into the slotted rebates in the Vari-fix back door (Fig1).
7. To achieve the correct assembly of the Vari-fix U-Bolt system, slacken the 2 No. M8 half nuts and tighten the 2 No. M8 Full nuts until the 4 raised lugs on the Vari-fix firmly engage with the post diameter (Fig1).
8. When secure, re-tighten the 2 no. M8 half nuts, which, as they are tightened, will force the tapered rota plugs into the slotted Vari-fix holes to form a weather proof seal Note:- This is particularly important as failing to tighten the M8 half nuts will compromise the IP rating and sealing of the PULSA casing.
9. Repeat this procedure for the other U-Bolt assembly.
10. Wire the incoming mains cable into the plug socket located on the gear tray.
L - Line
E - Earth (ensure that the Vari-fix earth continuity lead is wired in at the same time) (Fig 2)
N - Neutral
Fit the cable restraint clamp and terminal cover.
11. Refit the service plate.
12. Re-attach the PULSA body to the Vari-fix back door using the retained screws. Plug the mains input lead back into the main circuit board.
13. Finally close the body onto Vari-fix back plate and securely tighten the Tri-head fixings.

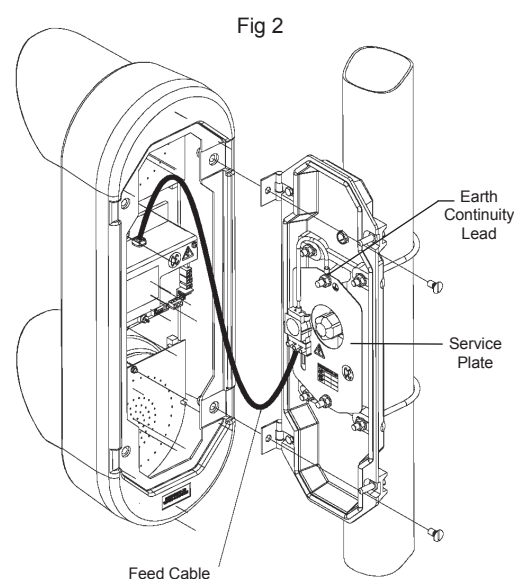
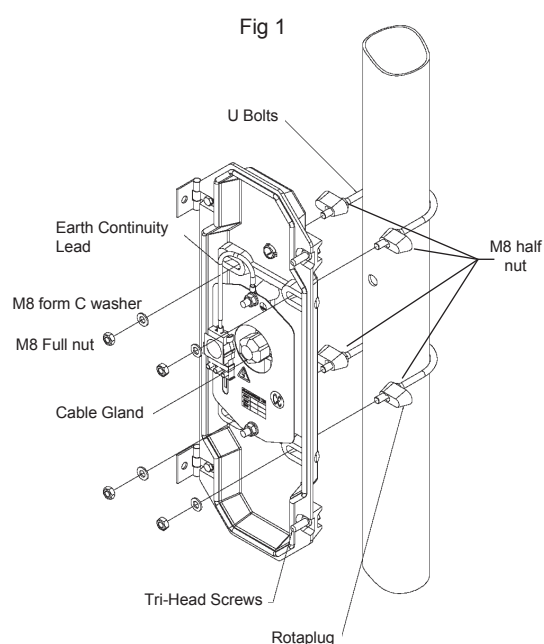

Simmons signs Limited reserves the right to alter or improve this guide without prior notice.

VARI-FIX U-BOLT AND BANDING CLEAT SETS

When installing the Pulsa, the Vari-fix system provides three fixed diameter options using 76mm, 89mm and 114mm stainless steel U-bolt sets and where the mounting post is of a larger diameter or irregular section, the Vari-fix banding cleat set can be used in conjunction with conventional stainless steel 20mm banding.

Sales Code

VAR/076/U - 76mm U-Bolt set
VAR/089/U - 89mm U-Bolt set
VAR/114/U - 114mm U-Bolt set
VAR/BAND - Banding Cleat set for universal fixing

PLATE FIXING

If the Pulsa has to be surface mounted onto a sign plate then again a specific set of fixings are required along with a copy of the appropriate template drawing.

Sales Code

VAR/PUL/PLTFX - Pulsa vari-fix plate fixing set c/w template.

OPERATION

The SMART PULSA features a 2 year programmable controller with manual over-ride by means of a concealed magnetic switch. The GPRS programming guide is available at www.simmons signs.co.uk

PROGRAMMING

If the calendar function is enabled, the SMART PULSA is programmed using the Simmons signs SIMPOD wireless transfer device (sold separately). Full details of operation can be found in the user guide supplied with the SIMPOD. Swipe the secret magnetic switch to activate communication between the PULSA and SIMPOD. See manual operation/override section.

The GPRS PULSA shares this same ability, but can also be programmed and monitored via the internet on <http://gprs.simmons signs.co.uk/> following account set up.

GPRS PULSA MODEM LED DESIGNATIONS

To see the Led designations and check the Led colours the front cover of the modem needs to be removed.

LED 1 (RED)	ON - External Power Supply Present
LED 2 (GREEN)	ON - GSM/GPRS connected
LED 2 (GREEN)	Flashes every 3 seconds, NO GPRS connection
LED 2 (GREEN)	Flashes every second, NO GSM/GPRS connection
LED 3 (ORANGE)	Flashes every 3 seconds, System OK
LED 4 (BLUE)	Flashes twice every second, Modem Comms OK

TEST BUTTON

Pressing the test button will illuminate the main LED arrays and perform system checks which will illuminate a number of green LED's on the main board. Our technical support team may ask you to perform this test should you report problems.

MANUAL OPERATION/OVER-RIDE

Manual operation provides the facility to operate the PULSA outside the times defined by the programmer or when the calendar function is disabled. This is useful for unforeseen operations such as on sports days or after hours events.

Manual operation is activated by a secret magnetic switch positioned at the bottom of the PULSA. When the magnetic key-fob (supplied) is swiped between two rivets at the bottom of the PULSA casing, an internal timer is activated which will operate the PULSA for a pre-set period before automatically switching off. To adjust the 'auto-off period' please see below.

NB: If the over-ride overlaps a programmed schedule then the program will have precedence.

To adjust the manual operation period, a rotary switch is provided on the main circuit board inside the PULSA. The switch has ten positions numbered 0 to 9. Each click of the switch advances the timer by 10 minutes, position 1 representing 10mins and 9 representing 90mins. In position 0 the manual operation timer is disabled and will require a second swipe to turn the PULSA off.

The GPRS PULSA can be over-ridden via web programming or via text message. Full instructions for this are available in the GPRS manual, available as a download in the 'customer area' of the Simmons signs website

DIP SWITCHES

A bank of DIP switches provides specialist operation of the PULSA. Under normal circumstances these should remain factory set. For normal operation, as described above, all but switch 3 will be in the ON position and switch 3 will be in the off position.

MAINTENANCE

Replacing LED clusters

1. Isolate the mains electrical supply before commencing any maintenance work.
2. Unclip the electrical connector to each LED cluster.
3. Remove the M4 fixings holding the LED clusters in place (2 fixings per cluster) with a 7mm spanner.
4. Carefully remove the LED clusters by sliding off the plastic threaded studs.
5. Fit the new LED clusters over the plastic threaded studs.
6. Refit the new fixings (2 full nuts and 2 Nylon washers per LED cluster).
7. Ensure full nuts are pinch tight (caution: do not over tighten as threaded studs are plastic).
8. Reconnect electrical connector to LED clusters and test.

Simmons signs Limited reserves the right to alter or improve this guide without prior notice.