

SAFETY FIRST

Ensure that the site is surveyed for buried services and that any electrical supply is isolated before commencing work.

All materials to be handled using suitable mechanical equipment or sufficient manpower for the weight of the item being handled.

TOOLS & MATERIALS REQUIRED

Tri-head Key.
5mm Allen key.
Electrical Screwdriver.

Side Cutters
13mm spanner
Ø14mm drill

PACKING LIST

Box 1 - Solar panel
Box 2 - LED LUA
Box 3 - Solar Panel support, LUA Bracket, battery and regulator.

INSTALLATION

1

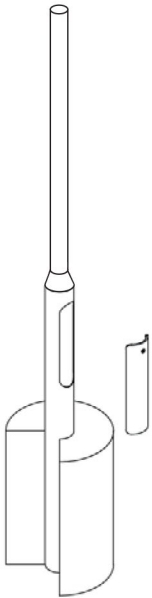

The Solar LUA is supplied as a kit designed to fit onto a pre-installed 89/168 column. The column manufacturer should be consulted to provide a column and foundation plan suitable for the equipment to be mounted and environmental conditions peculiar to the site.

Weights and dimensions of the solar LUA equipment are shown overleaf to help with calculating the loads.

2

Assemble the solar panel support by uncoiling the solar panel output lead and feeding it through the panel support bracket as shown.

Place the bracket over the aperture in the panel back moulding and secure with the 4 Tri-head screws supplied.

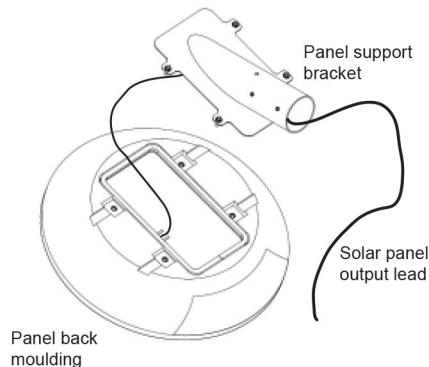

3

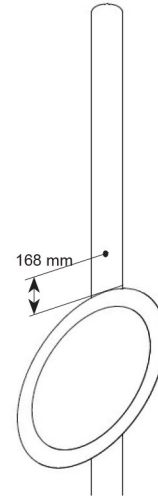

Fix the sign to be illuminated onto the post in its final position.

Mark and drill a 14mm cable entry hole in the post 168 mm from the top of the sign and in line with its centre.

For a double sided installation repeat on the other side of the post.

De-bur and surface protect the bare faces of the drilled hole.

4

Slide the LUA through-bracket over the top of the post and down to align with the drilled hole.

Lock this in place with the supplied M8 x 48 socket set screw.

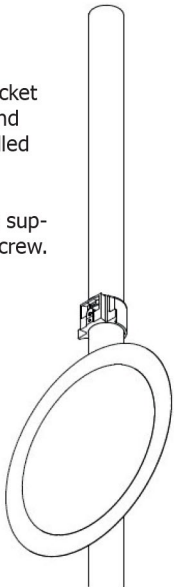

5

Take the solar panel assembly and feed the solar output lead down the post from the top so that it emerges in the column base housing.

Place the solar panel assembly on the top of the post and align it to point directly South.

Ensure that nothing impedes the solar panels view of the sun.

Tighten the grub screws to lock the solar panels assembly onto the post.

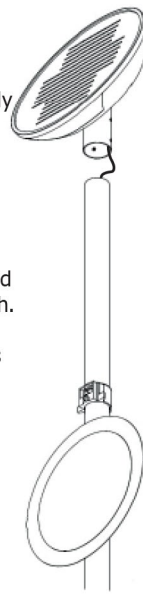

6

Fix the Solar LUA sign-light to the through-bracket following the instructions supplied with the LUA.

Pass the LUA supply cable down the post via the drilled hole and into the column base housing

Repeat this step for a double sided installation.

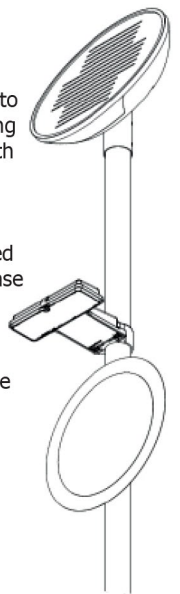

7

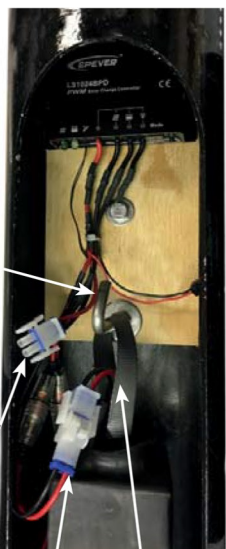

Moving to the column base remove the existing wooden board and replace with the regulator board assembly supplied

In the following steps please ensure that the connections are made in the following order :

1. Battery
2. Load
3. Solar panel.

Take the battery pack and hang it from the hook on the regulator board. Connect the battery to the battery connector.

For double sided installations a second battery pack is hung from the hook using the extension loop.

Connect the load lead coming from the LUA to the corresponding connector coming from the regulator. For a double sided installation, a two way adaptor is supplied.

Connect the solar panel then locate the regulator On/Off switch and press to switch on. After a short delay LUA will illuminate briefly before the photo-cell switches off .

Finally replace the column door.

REGULATOR STATUS

Charging Status LED Indicator	Green	On Solid	Normal
	Green	Fast Flashing	Over Voltage
Battery Status LED Indicator	Green	On Solid	Normal
	Green	Slowly Flashing	Full
	Orange	On Solid	Under Voltage
	Red	On Solid	Over Discharged
Radix Point of Digital tube (Load indicator)	Red	On Solid	Load ON
	Red	Slowly Flashing	Over Load
	Red	Fast Flashing	Short Circuit

CIRCUIT DIAGRAM

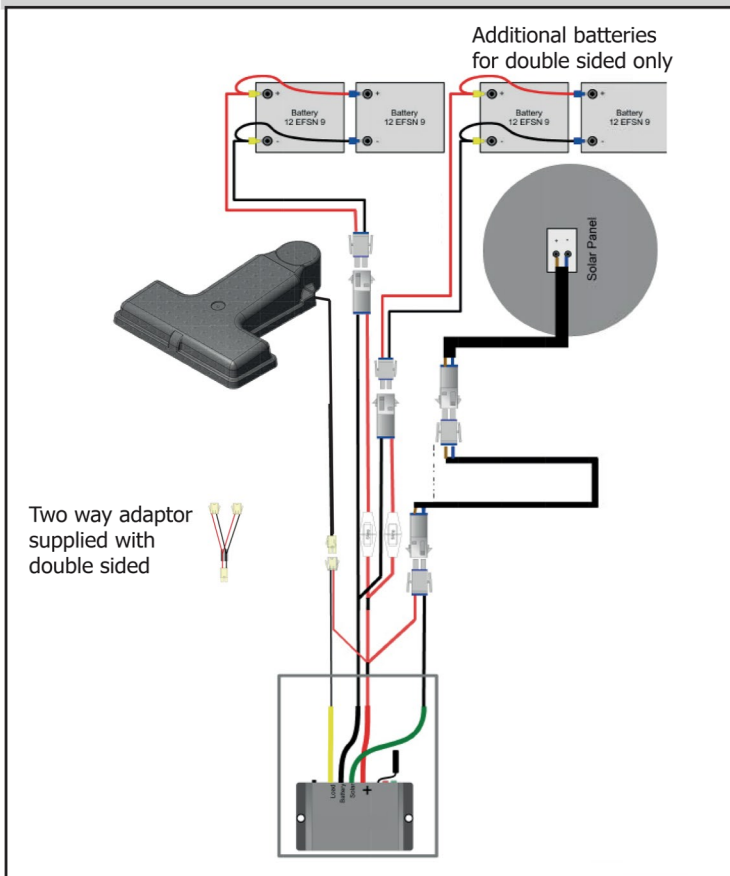

DIMENSIONS

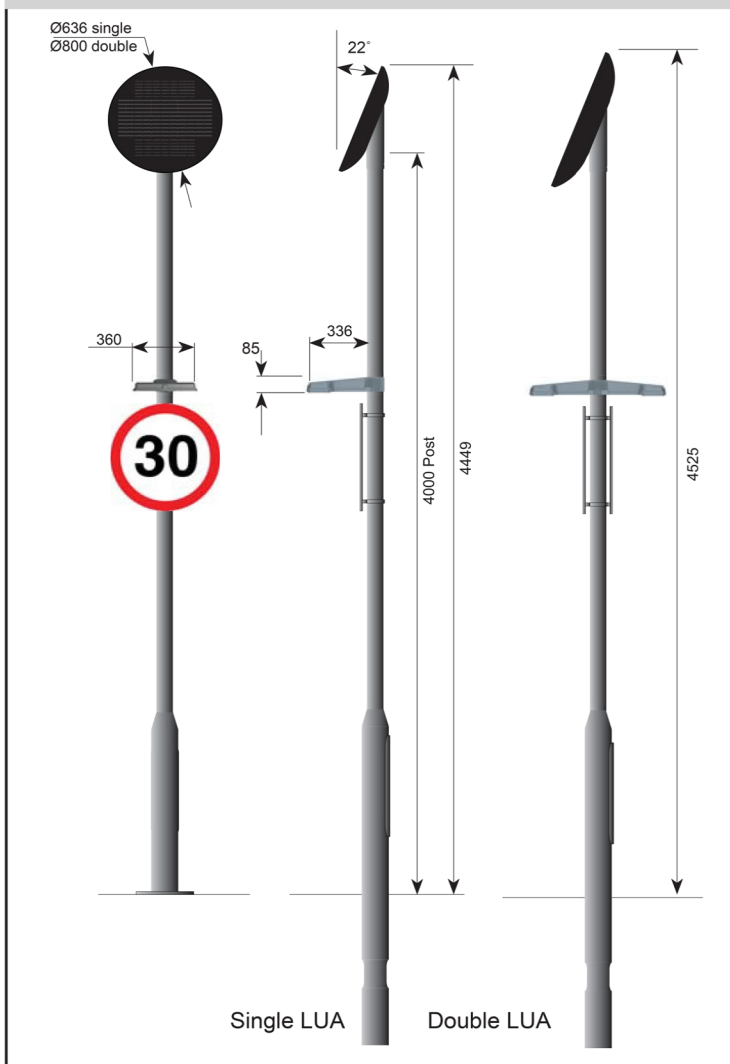

PRODUCT WEIGHTS

Solar LUA	3 Kg
Solar Panel	11.5 kg Single, 13 kg Double
Battery	5.1 kg per pack

Simmons signs Limited reserves the right to alter or improve this guide without prior notice.