

### SAFETY FIRST

Isolate the mains electrical supply before commencing installation.

All electrical work must be carried out by suitably qualified engineers in accordance with the latest IEEE regulations.

### TOOLS REQUIRED

Tri-head key  
5mm AF Allen key  
13mm Ring open ended spanner

Philips screwdriver  
Small spade electrical screwdriver  
Wire strippers

### FITTING PROCEDURE

1. Open the Pulsa unit by unscrewing the two Tri-head screws on the back of the unit.
2. You may find the following operations easier by removing the Vari-fix back door from the PULSA. This is done by unplugging the two LED array feed cables and the mag switch cable, then remove and retain the two countersunk hinge mounting screws using a 5mm AF Allen key.
3. Assuming that the mounting post has already been drilled, deburred and surface protected, feed the supply cable through the supply post and into the back of the Vari-fix back door through the cable entry gland (Fig1).
4. Ensure that the cable entry gland is tightened onto the incoming supply cable. The gland is fitted with a standard insert to accommodate cable sizes 9-14mm. An extra insert to accommodate cable sizes 13-18mm is included in a grip seal bag in the body of the Pulsa.
5. Select the appropriate Vari-fix post fixing kit for the mounting post diameter and remove the M8 form C washers and M8 Full nuts (Fig1).
6. With the back door located in line with the post cable gland, offer one of the U-Bolts around the mounting post and penetrate the two projecting Rotaplugs into the slotted rebates in the Vari-fix back door (Fig1).
7. To achieve the correct assembly of the Vari-fix U-Bolt system, slacken the 2 No. M8 half nuts and tighten the 2 No. M8 Full nuts evenly until the 4 raised lugs on the Vari-fix firmly engage with the post diameter (Fig1).
8. When secure, re-tighten the 2 no. M8 half nuts, which, as they are tightened, will force the tapered rota plugs into the slotted Vari-fix holes to form a weather proof seal Note:- This is particularly important as failing to tighten the M8 half nuts will compromise the IP rating and sealing of the PULSA casing.
9. Repeat this procedure for the other U-Bolt assembly.
10. Wire the incoming mains cable into the plug socket located on the gear tray.  
L - Line  
E - Earth (ensure that the Vari-fix earth continuity lead is wired in at the same time)  
N - Neutral  
Fit the cable restraint clamp and terminal cover.
11. Plug the LED feed cables and the mag switch lead back into their sockets .
12. Re-attach the PULSA body to the Vari-fix back door using the retained screws.

13. The LED Pulsa has a built in timer which will operate for a pre-set period following activation. The timer is adjusted using a rotary switch mounted on the Pulsa circuit board. Rotate the switch clockwise to increase time. Each click extends the time by 10 minutes up to a maximum of 150 minutes. Set the switch to the desired time period. e.g. 3 = 30mins,

14. Remove the magnetic key fob from the metal door plate before closing the Pulsa and securing with the two tri-head screws. Connect the power.

15. To activate the Pulsa, take the magnetic key fob and swipe from back to front between the rivets at the bottom of the Pulsa. This will trigger the timer for the pre-set period.

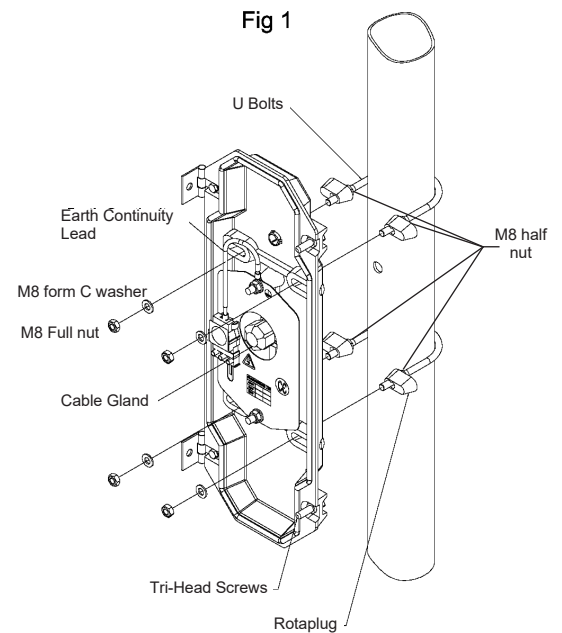

Fig 1

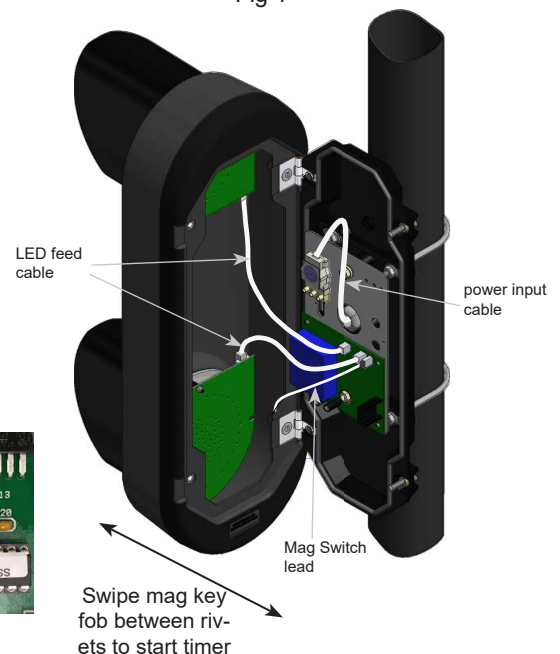

Fig 2

