

### SAFETY FIRST

Ensure that the supply voltage is suitable for the units being installed.

Isolate the electrical supply before commencing any installation or maintenance work.

All electrical work must be carried out in accordance with the latest IET wiring regulations (BS7671) by suitably qualified engineers.

### TOOLS REQUIRED

Tri-head key.  
PZ2 Pozidriv screwdriver.

**Fixings supplied with retrofit light unit:**  
LED light unit.  
3mm stippled lens.

Weight	Size	Packaging
Gear Tray 1.5Kg Inc. Nodes 1.75Kg	548 x 142 x 64mm	Plain Carton with anti-static bubble wrap

## INSTALLATION

**1** Loosen the 6 x M8 Tri-head screws and hinge open the hinged cover. (Fig. 1)

Remove and dispose of the existing 1mm clear sacrificial lens and replace with the 3mm stippled lens, ensuring the smooth side is facing out.

**2** Loosen the 2 x M6 retainer screws securing the light unit. (Fig. 2)

Slide left and lift the light unit out of the Hermit body and disconnect the three-way power socket on the rear of the light unit.

Dispose of the original light unit in accordance with the current WEEE directive.

**3** Offer the replacement LED light unit into the Hermit casing using the available grip points.

Refit the three-way power socket into the light unit, then place it over the 2 x M6 retainer screws and slide right into the keyhole slots.

**4** Secure the M6 retainer screws to 2 Nm, ensuring that no cables become trapped.

Close the hinged cover and secure by tightening the 6 x M8 Tri-head screws. (Fig. 1)

Reconnect the mains power supply in accordance with the latest IET wiring regulations (BS7671) and test the Hermit.

Simmons signs Limited reserves the right to alter or improve this guide without prior notice.

Fig. 1

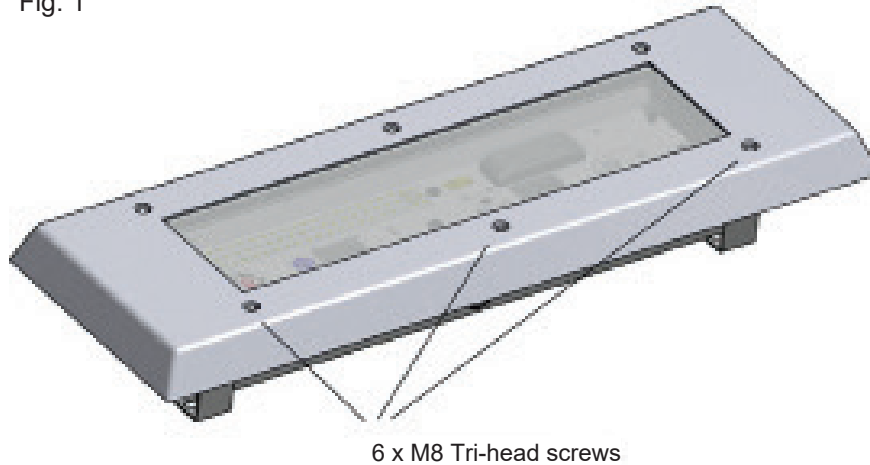
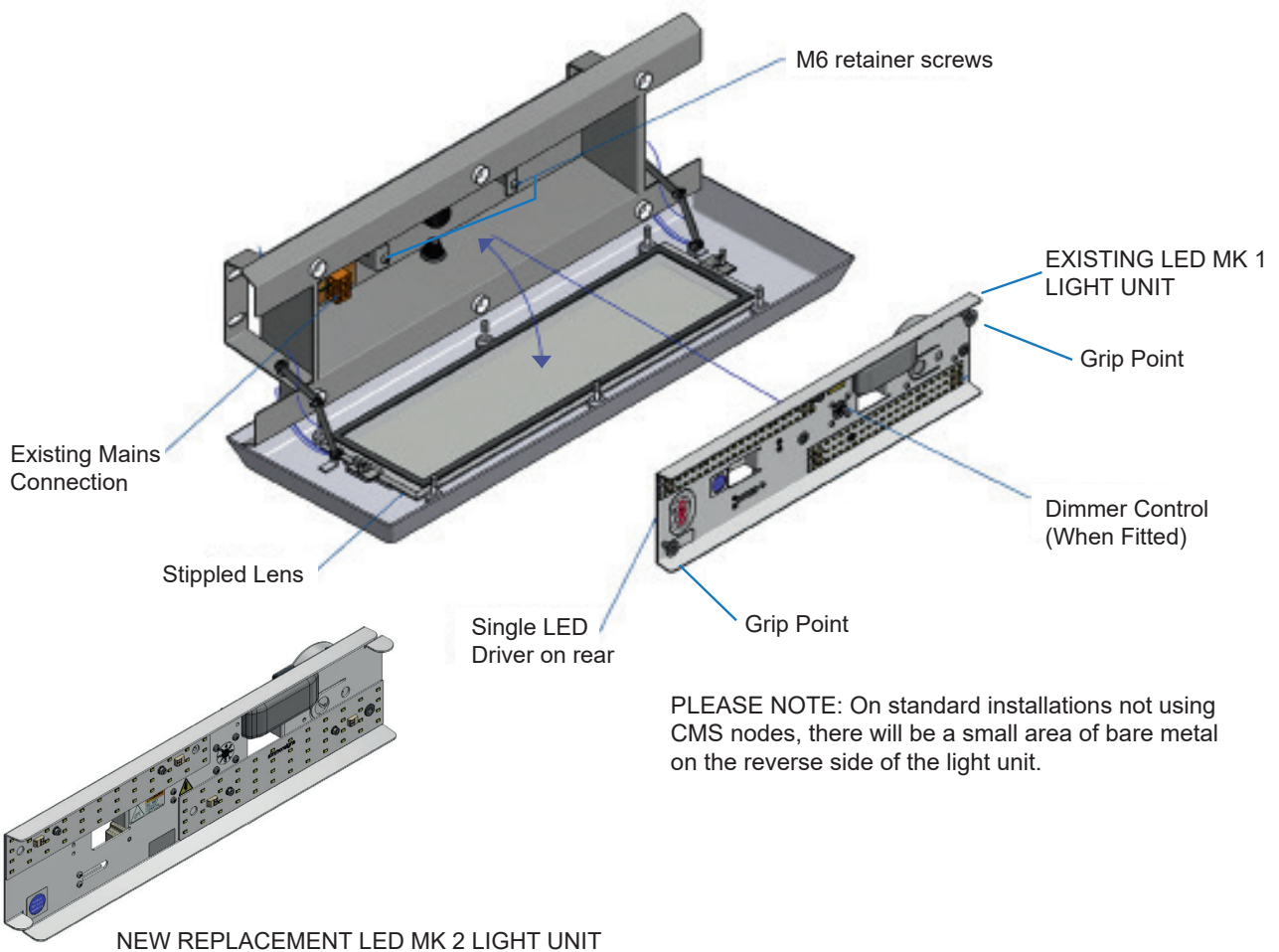

Fig. 2



Simmons Limited reserves the right to alter or improve this guide without prior notice.