

SAFETY FIRST

Ensure that the site is surveyed for buried services and that any electrical supply is isolated before commencing work.

All materials to be handled using suitable mechanical equipment or sufficient manpower for the weight of the item being handled.

TOOLS & MATERIALS REQUIRED

Tri-head Key.
5mm Allen key.
Electrical Screwdriver.

Side Cutters
13mm spanner
Spirit Level
Concrete - ST2 BS8500

PACKING LIST

Box 1 - Solar panel
Box 2 - LED Beacon & shroud.
Box 3 - Solar Panel support, battery and regulator
Unboxed - Post.

INSTALLATION

1 Excavate a foundation hole with reference to the table below.

Planted root (800 deep)

Administrative Area*	Non-Coastal**	Coastal**
Extra light	Ø 375	Ø 425
Light	Ø 425	Ø 475
Medium	Ø 475	Ø 500
Heavy	Ø 500	Ø 575
Extra Heavy	Ø 600	Ø 675

The table assumes poor ground conditions.

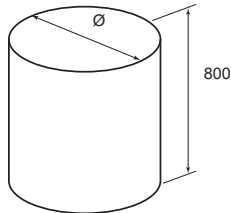

* Administrative areas are defined in PD6547, Annex A
** Coastal is defined PD6547 as within 5km of the mean high spring tide height.
If posts are to be installed in exposed locations or where local wind funnelling or topography is significant, specialist advice should be sought.

2

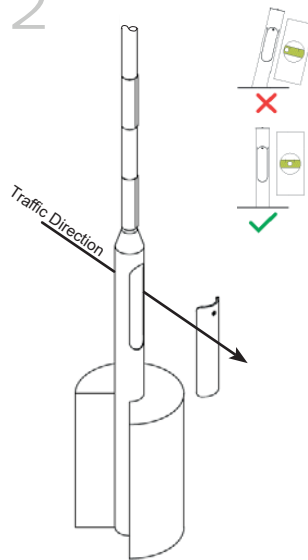

Make a mark on the post 800mm up from the bottom to represent finished ground level. Insert the column base into the centre of the excavated hole with the door facing away from the oncoming traffic.

Backfill with standardised prescribed concrete 'ST2' to BS 8500 up to the ground level marker on the post. Use a spirit level to ensure that it is vertical.

Note: allow the concrete to set before continuing with the installation.

Remove and retain the column door.

3

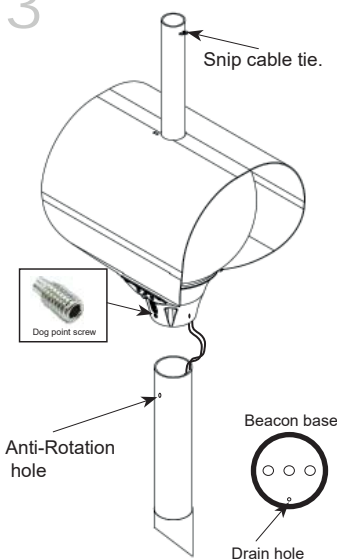

Take the Belisha beacon assembly and uncoil the two low voltage drop leads. Pass both leads down the post into the base housing. Check that the gallery drain hole is clear before placing the beacon on top of the post ensuring the beacon faces are towards the traffic.

Lock the beacon onto the post by tightening the gallery socket screws. One of the screws has a dog point which should align with the pre-drilled anti-rotation hole near the top of the post.

Snip the transport cable tie at the top of the solar panel spigot. This will release the PV connection cable.

4

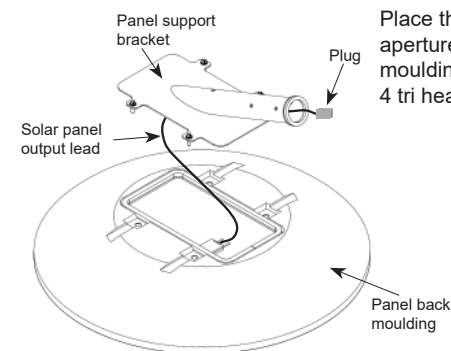

Assemble the solar panel support by uncoiling the solar panel output lead and feeding it through the panel support bracket as shown.

Place the bracket over the aperture in the panel back moulding and secure with the 4 tri head screws supplied.

Simmons signs Limited reserves the right to alter or improve this guide without prior notice.

5

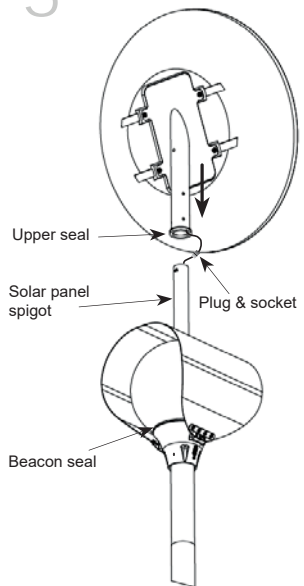

Pull the solar output lead out of the solar panel support bracket and carefully lift the solar panel assembly above the solar panel spigot. Connect the solar output lead to the PV connection lead using the corresponding plug and socket.

Place the solar panel over the solar panel spigot taking care not to trap the solar output cable.

Rotate the panel to point directly south, ensuring that the panel has an unobstructed view of the sun.

Check that the upper seal is compressed against the shroud and the beacon is seated against the beacon seal. Tighten the 4 grub screws to lock the panel in place.

6



Moving to the column base, fix the regulator board in the base with the 8mm hex screw supplied.

At this point ensure that the root of the column base will not fill with rising water above ground level. If there is a risk of this, create a drain hole in the column near ground level in order to protect the batteries from water ingress.

The next step (7) is to install the batteries and make the connections. Please ensure that the connections are made in the following order :

1. Battery
2. Load
3. Solar panel.

7

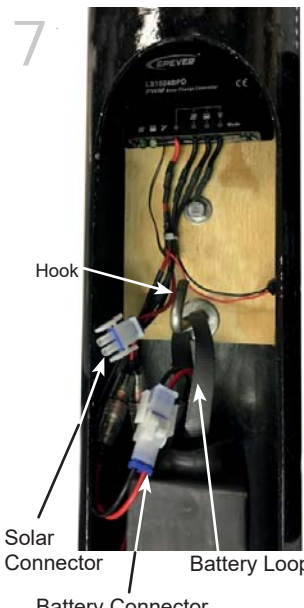

Take the first battery pack, which is hung from the hook on the regulator board using the extension loop supplied. This will position the battery in the lower position. Connect the battery to the longer battery connector.

Repeat for the second battery pack, which is hung from the same hook without the extension loop. This will position the battery in the higher position. Connect the battery to the remaining battery connector.

Make the remaining connections to the load and finally the solar panel.



Locate the regulator On/Off Switch and press to switch on.

After a short delay the SOLABEL will start flashing.

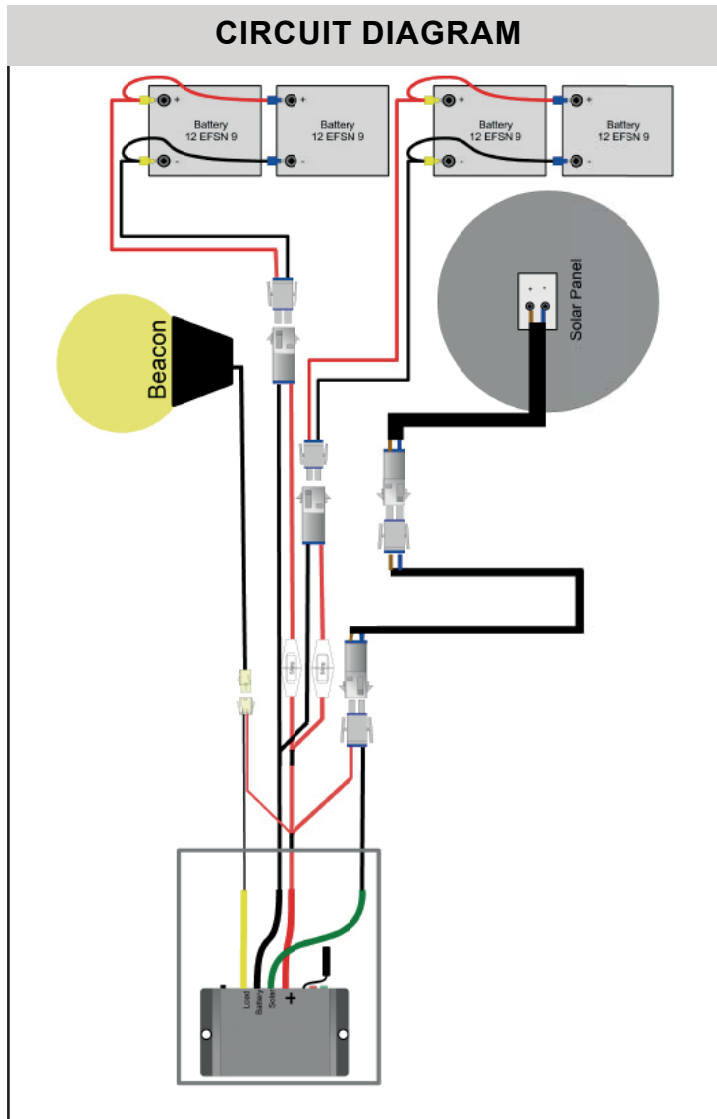
Finally replace the column door.



REGULATOR STATUS

Indicator	Color	Status	Instruction
 PV	Green	On Solid	PV connection normal but low voltage(irradiance) from PV, no charging
	Green	Slowly Flashing(1Hz)	In charging
	Green	Fast Flashing(4Hz)	PV reverse polarity
	Green	OFF	No PV voltage(night time) or PV connection problem
 Battery	Green	On Solid	Normal
	Green	Slowly Flashing(1Hz)	Full
	Green	Fast Flashing(4Hz)	Over voltage
	Orange	On Solid	Under voltage
	Red	On Solid	Over discharged
	Red	Fast Flashing(4Hz)	Battery Overheating

Simmons signs Limited reserves the right to alter or improve this guide without prior notice.