

SAFETY FIRST

Isolate the mains electrical supply before commencing installation.

All electrical work must be carried out in accordance with the latest IET wiring regulations (BS7671) by suitably qualified engineers.

Ensure the voltage of the signlight head is compatible with the mains supply input.

TOOLS REQUIRED

- 13mm socket spanner
- Philips screwdriver
- Tri-head key
- M4 Allen key
- 3mm spade end screwdriver
- Earth Pack (supplied) containing:
 - 3 way socket c/w cable clamp and cover
 - 1 No. 6mm² flexible earth cable c/w 8mm ring terminal and spade terminal

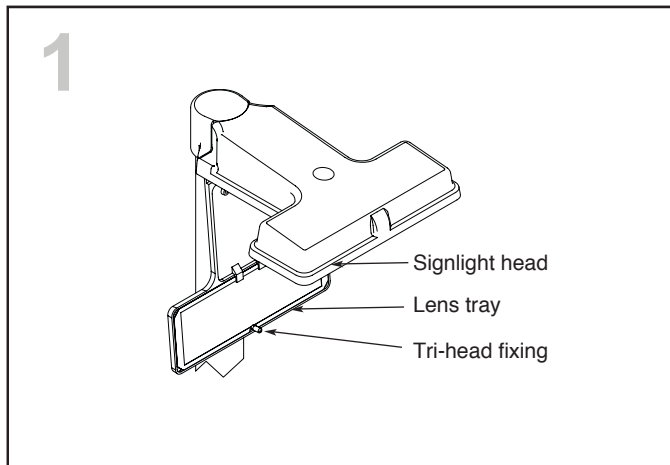

Release the Tri-head fixing and hinge the lens tray down.

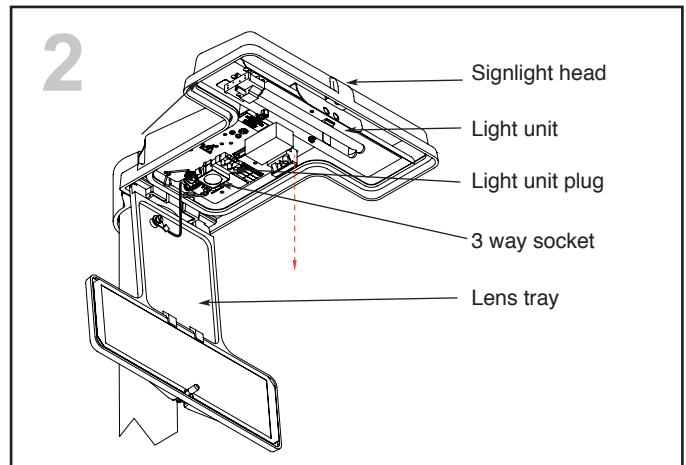

Remove the existing light unit by unplugging the 3 way socket and unlatching it from the signlight head. This is done by pushing the light unit back towards the post and at the same time pulling down gently.

Be aware of any additional equipment that may be attached to the LUA body which will need to be disconnected. Additional equipment will typically be remote monitoring nodes and certain photocells.

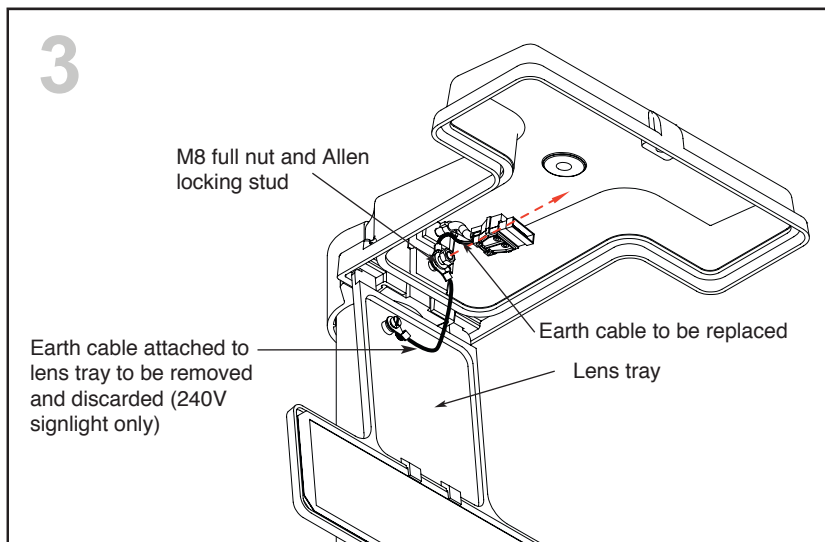

With the existing light unit removed, disconnect the two earth cables by releasing the M8 nut and removing the ring terminals on the locking stud.

Unhook the lens tray and remove together with the earth cable which is attached at one end to the lens tray.

Take the replacement earth cable located in the supplied earth pack, and put the 8mm ring terminal over the end of the grub screw, securing it using the M8 washer and M8 full nut. The spade terminal from the earth cable needs to be wired into the same terminal as the earth end of the supply cable.

Ensure the Allen locking stud is fully tightened using the M4 Allen key.

Check that the earth screw assembly meets the requirements of the current IET regulations. A replacement earth kit is available to order should this be required.

Note: There are no earth cables on the 24V signlight.

The lens, lens tray and light unit are no longer needed and should be recycled appropriately.

Simmons signs Limited reserves the right to alter or improve this guide without prior notice.

4

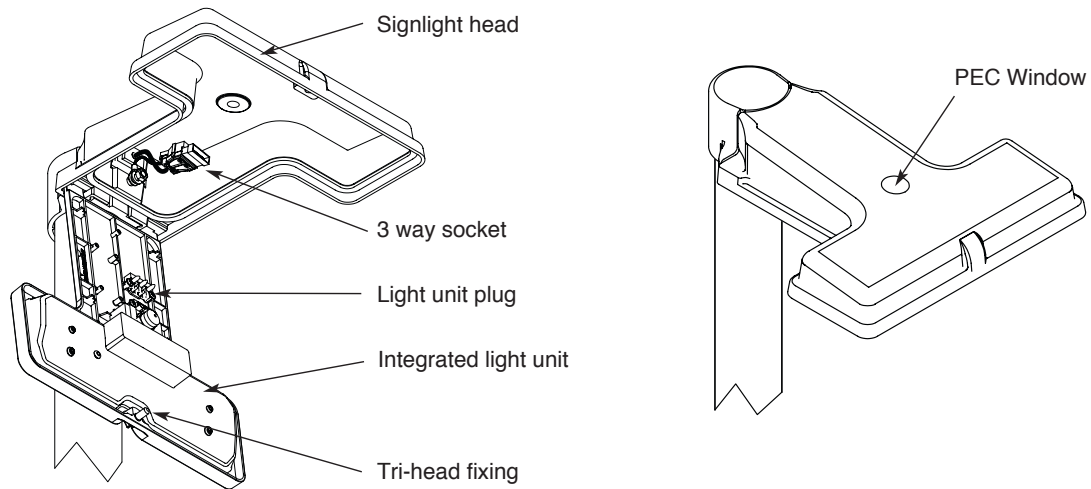

Hook the integrated light unit onto the signlight head as shown.

Connect the 3 way socket into the light unit plug and reconnect any additional equipment that may be attached to the LUA body.

Make a final visual check of the light unit to ensure that any photocell has not moved during transport and lines up with the PEC window, then hinge up the integrated light unit and secure with the Tri-head fixing.

Finally: Reconnect the mains power supply and test the unit.

Simmons signs Limited reserves the right to alter or improve this guide without prior notice.