

SAFETY FIRST

Ensure that the site is surveyed for buried services and that any electrical supply is isolated before commencing work.

All materials to be handled using suitable mechanical equipment or sufficient manpower for the weight of the item being handled.

TOOLS & MATERIALS REQUIRED

Tri-head Key.
5mm Allen key.
Electrical Screwdriver.

Side Cutters
13mm spanner
Ø14mm drill

PACKING LIST

Box 1 - Solar panel
Box 2 - Solar PULSA
Box 3 - Solar Panel support, 89mm U Bolt Kit, battery and regulator.

INSTALLATION

1

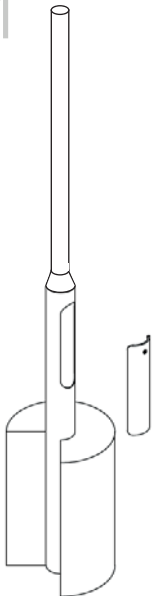

The Solar PULSA is supplied as a kit designed to fit onto a pre-installed 89/168 column. The column manufacturer should be consulted to provide a column and foundation plan suitable for the equipment to be mounted and environmental conditions peculiar to the site.

Weights and dimensions of the solar PULSA equipment are shown overleaf to help with calculating the loads.

2

Assemble the solar panel support by uncoiling the solar panel output lead and feeding it through the panel support bracket as shown.

Place the bracket over the aperture in the panel back moulding and secure with the 4 Tri-head screws supplied.

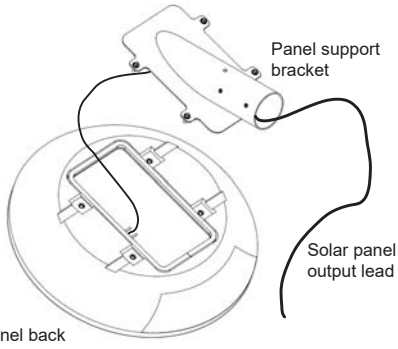

Panel back moulding

3

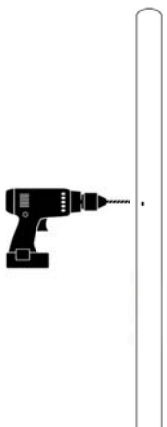

Drill a Ø14mm hole in the post at the required height (2421mm from ground level to give a height of 2100mm to the base of the PULSA) -

Surface protect the bare metal and ensure the hole is free from burrs and sharp edges.

4

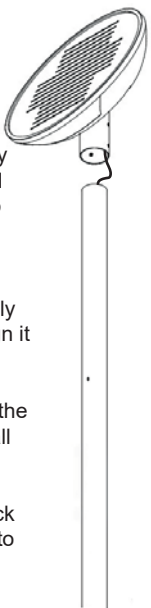

Take the solar panel assembly and feed the solar output lead down the post from the top so that it emerges in the column base housing.

Place the solar panel assembly on the top of the post and align it to point directly South.

Ensure that nothing impedes the solar panels view of the sun all year round.

Tighten the grub screws to lock the solar panels assembly onto the post.

5

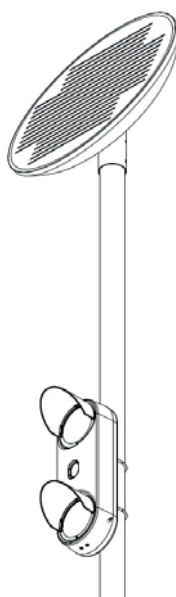

Fix the PULSA to the post in accordance with the standard PULSA installation instructions.

Pass the PULSA supply cable down the post via the drilled hole and into the column base housing.

6

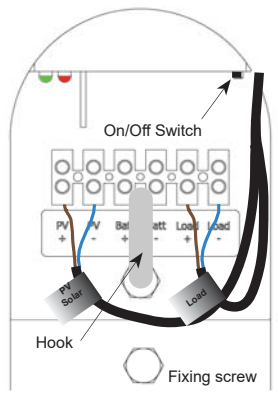

Moving to the column base remove the existing wooden board and replace with the regulator board assembly supplied

Connect the Solar panel output lead to the PV terminals and the PULSA supply cable to the Load terminals as shown.

Simmons signs Limited reserves the right to alter or improve this guide without prior notice.

7

Take the battery pack and hang it from the hook on the regulator board. Connect the battery to the battery connector.

Repeat for the second battery pack which is hung from the same hook using the extension loop.

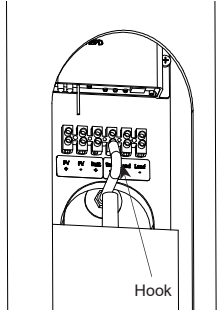

Locate the regulator On/Off Switch and press to switch on.

The PULSA will flash briefly.

Finally replace the column door.

8

The PULSA can now be programmed with switching times.



SMART PULSA

Use the SIMPOD transfer device to upload switching data to the PULSA Wirelessly.



GPRS PULSA

Use the SIMPOD transfer device or the dedicated Website to upload switching data to the PULSA.



Ensure that the GPRS installation card is completed and handed to the Website administrator.

Please see the SMART PULSA and GPRS PULSA user guides for more details.

REGULATOR STATUS

Indicator	Colour	Status	Instruction
PV	Green	On Solid	PV Connection normal but low voltage (irradiance) from PV, not charging.
	Green	Flashing (1Hz)	In Charging
	Green	Flashing (4Hz)	PV reverse polarity
Battery	Green	OFF	No PV voltage (night time) or PV connection problem
	Green	On Solid	Normal
	Green	Flashing (1Hz)	Full
	Green	Flashing (4Hz)	Over voltage
	Orange		Under voltage
	Red		Over discharged
Red		Battery overheating	

CIRCUIT DIAGRAM

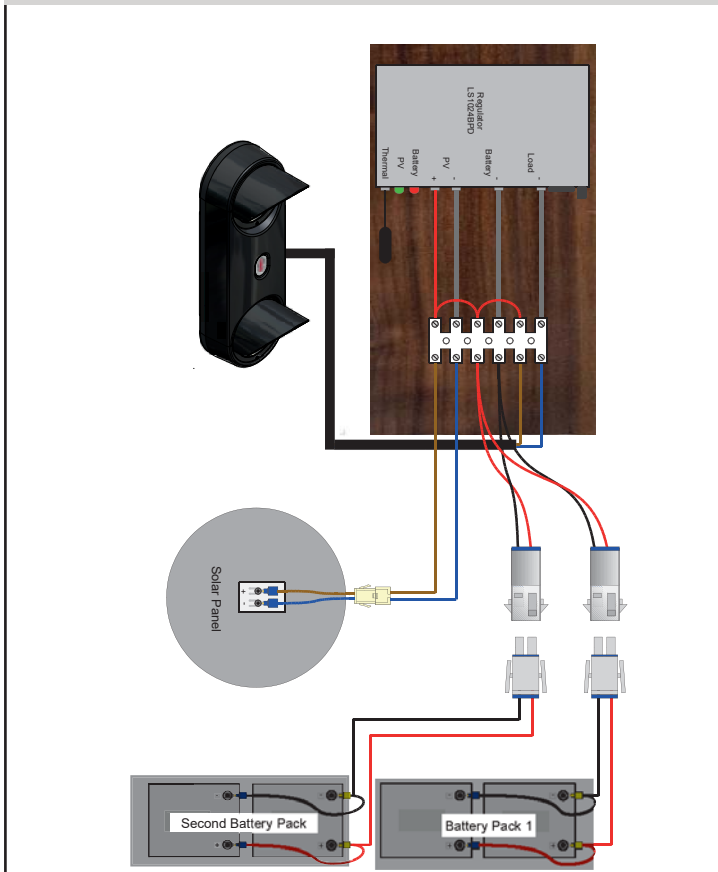

DIMENSIONS

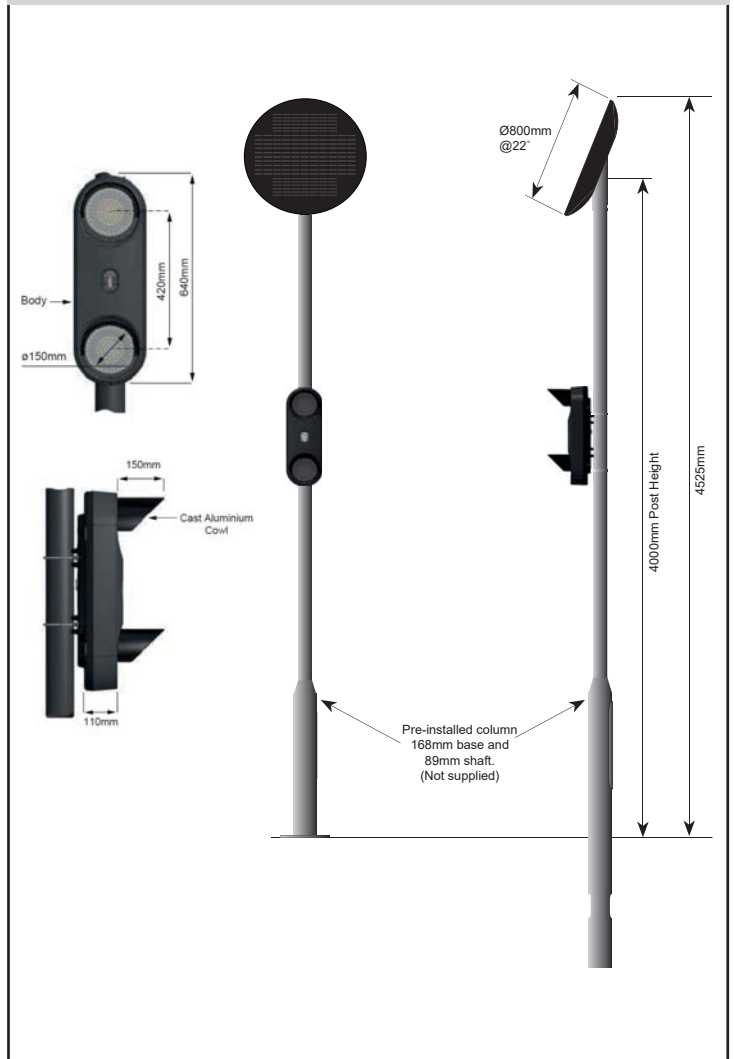

PRODUCT WEIGHTS

Solar PULSA	3 Kg
Solar Panel	13 kg
Battery	5.1 kg per pack x 2

Simmons signs Limited reserves the right to alter or improve this guide without prior notice.