

Trough Mounted

SAFETY FIRST

Ensure that the site has been surveyed for buried services before commencing excavation.

Suitable mechanical equipment and sufficient manpower must be used for the weight of the items being handled.

TOOLS REQUIRED

½" drive socket wrench
19mm deep drive socket and
19mm spanner
4mm Allen Key
Spirit level
14mm drill bit for ChemFix Studs
ChemFix Kit

If a D606 plate sign is being fitted, these will also be needed:
13mm socket
5mm Allen key

Concrete 'Gen 1' to BS 8500 or equivalent.

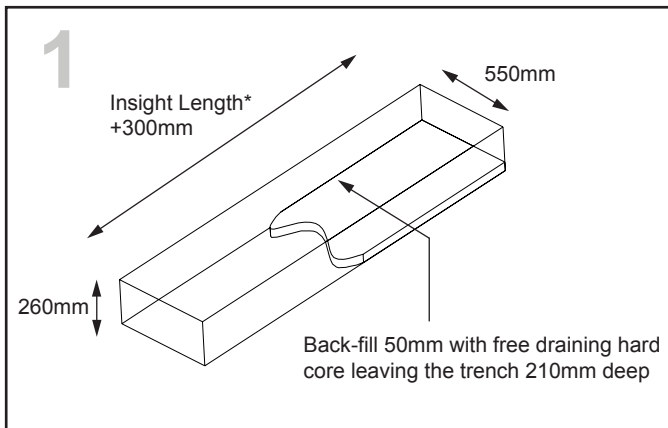

Excavate and prepare the foundation trench as shown above.

Then fill with concrete 'Gen 1' to BS 8500 or equivalent to 50mm below ground level.

*For Insight length, refer to the site specific plan supplied with the Insight or, alternatively, measure the assembled foundation.

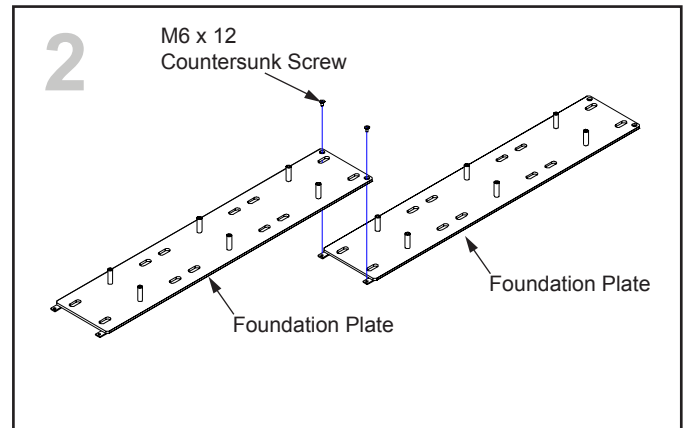

Assemble the Foundation Plates.

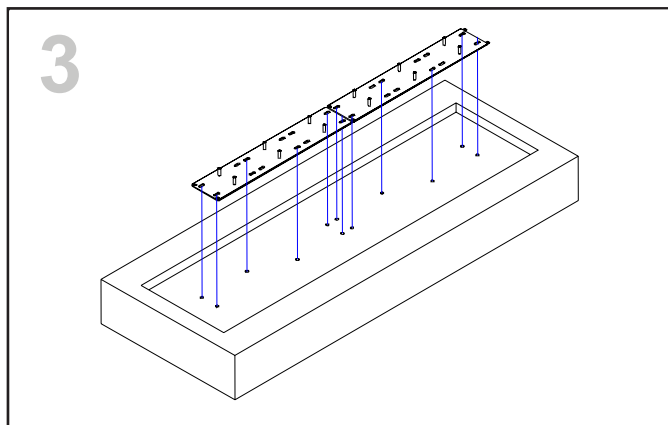

Use the assembled foundation plate as a template to mark on the substrate where the fixing holes are to be drilled.

Ensure the edges of the foundation plate are parallel to the edges of the foundation

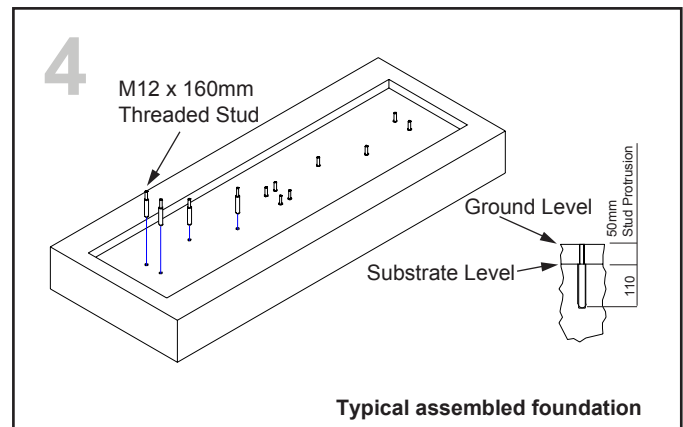

Drill the $\varnothing 14$ mm holes x 110mm deep and thoroughly clean to remove all dust and debris to ensure a good resin bond, using the cleaning equipment supplied with the ChemFix kit.

Fit the M12 x 160mm threaded studs (supplied) into the holes, leaving 50mm protruding from the substrate.

Simmons signs Limited reserves the right to alter or improve this guide without prior notice.

Trough Mounted

5

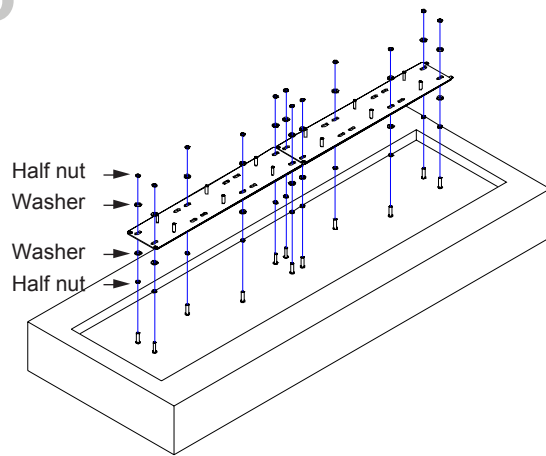

Screw M12 half nuts onto each of the studs, followed by a flat washer.

Place the assembled foundation plate over the studs and secure with another half nut and washer.

6

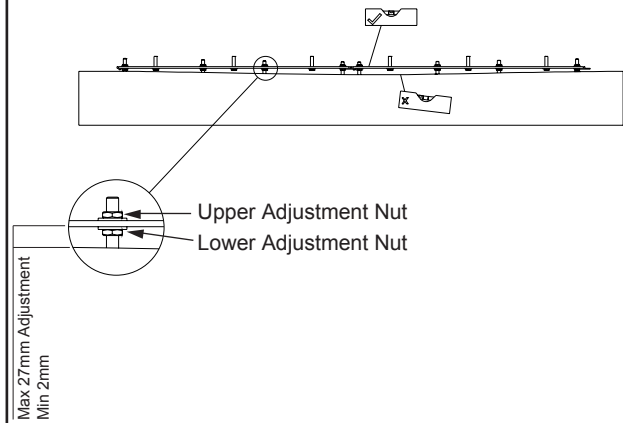

Level the foundation plate by adjusting the nuts above and below.

Ensure that all the nuts are fully tightened when levelling is complete.

7

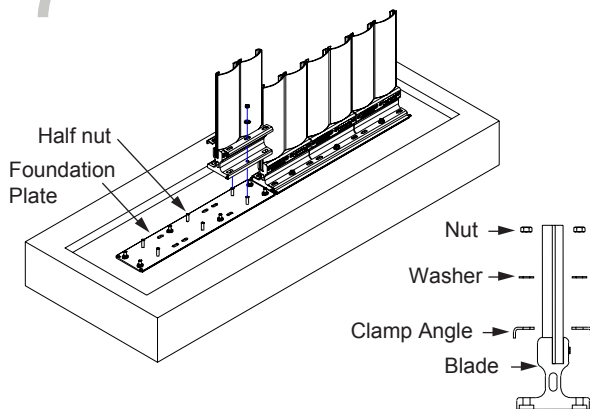

Referring to the supplied site specific plan, place the blades over the fixed studs on the foundation plate.

Retain the blades in place using clamp angles, washers and nuts.

8

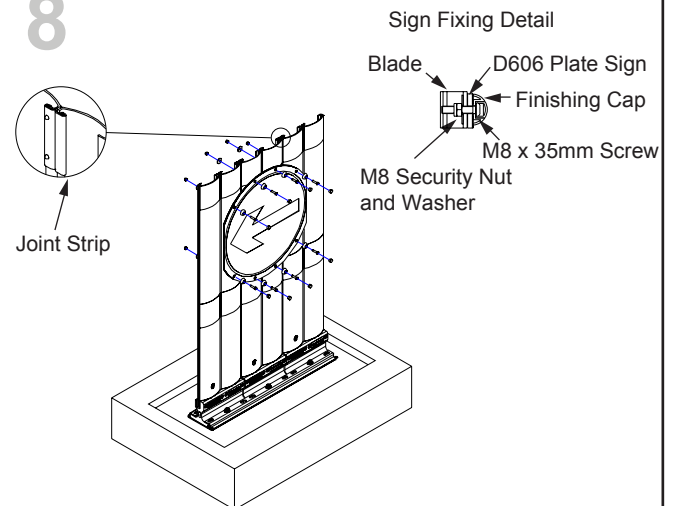

If the Insight has been supplied with a separate D606 plate sign, fix it to the blades with the screws provided.

Engage the joint strips at the top of each sign module.

Simmons signs Limited reserves the right to alter or improve this guide without prior notice.