

SURFACE MOUNTED WEEBOL FLEX

Tools required

Hammer drill and Ø20mm masonry bit.
19mm A/F combination spanner.
Fixing kit required – WBLF/SM/FIX

Safety First

Please ensure all safety elements are considered prior to installation, i.e. Any buried services, oncoming traffic etc.

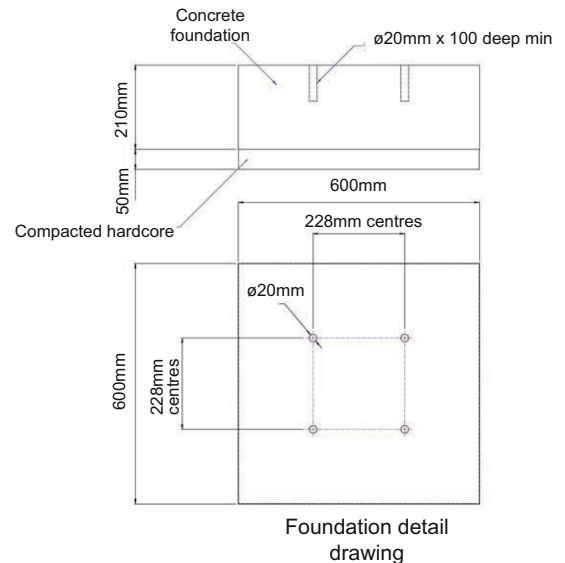
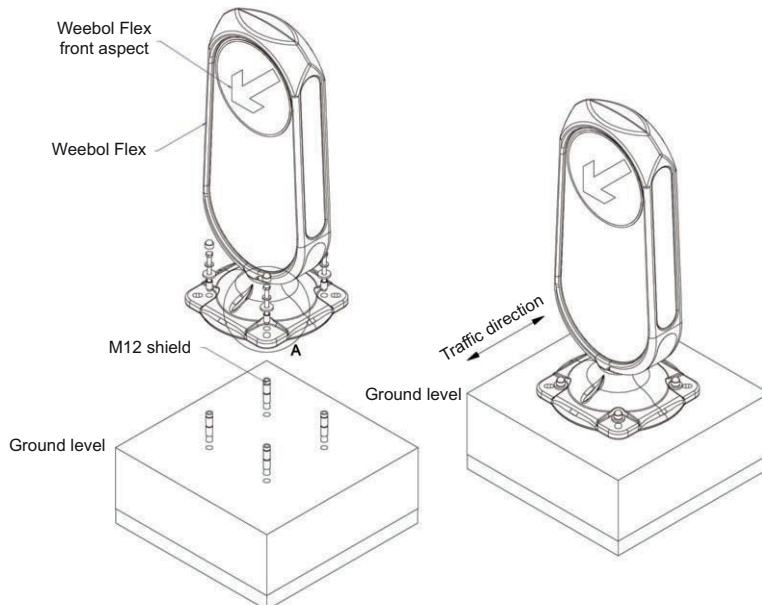
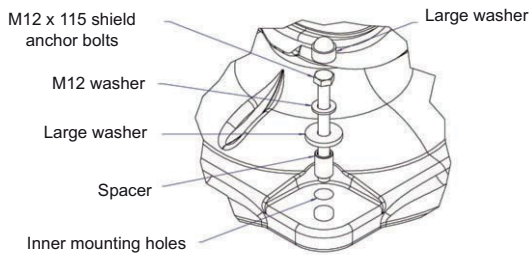

Installation

1) The surface mounted fixing kit is ideal for installing the Weebol Flex to an existing concrete surface. It is essential that the surface is sound and is equivalent to a new concrete pad 600 x 600 x 260 deep. For new installations requiring the laying of wet concrete we recommend our foundation cage system.

4) Drill 4 No Ø20mm holes at 100mm minimum depth as per "Foundation detail drawing".

5) Place 4 M12 x 115 anchor shields into the holes.

6) Align the Weebol Flex inner mounting holes over the anchor shields - paying careful attention to the orientation of the Weebol Flex front aspect.

7) Place 4 spacers into the mounting holes and secure in place using the M12 x 115mm anchor bolts, M12 washers and large washers.

8) Place 4 white plastic caps over the exposed bolt heads.

Note – Failure to follow these instructions may result in premature failure of the product.

Simmons signs Limited reserves the right to alter or improve this guide without prior notice.