

### SURFACE MOUNTED WEEBOL FLEX – FOUNDATION CAGE

#### Tools you will require

19mm A/F combination spanner  
Fixing kit required - WBLF/FDN

**Safety First** - Ensure the site has been surveyed for buried services before commencing excavation.

#### Installation

1. Excavate a hole 600mm wide x 600mm long x 260mm deep - Figure B.
2. Place 50mm deep hardcore in the base of the hole.
3. Place the pre assembled anchor frame/anchor bar assembly into the hole - Figure A

**Note:** Ensure that the top of the anchor frame is set at ground level and that the anchor bars are in the correct orientation in relation to the traffic flow.

4. Fill the excavation with concrete up to ground level and allow to set.
5. Remove the M12 full nuts.
6. Place the Weebol Flex over the 4 M12 anchor bars and nylon spacers - Figure B
7. Secure fix the Weebol Flex in position using 4 M12 large washers and M12 full nuts.
8. Place a white plastic cap over each of the M12 nyloc nuts.

Figure A

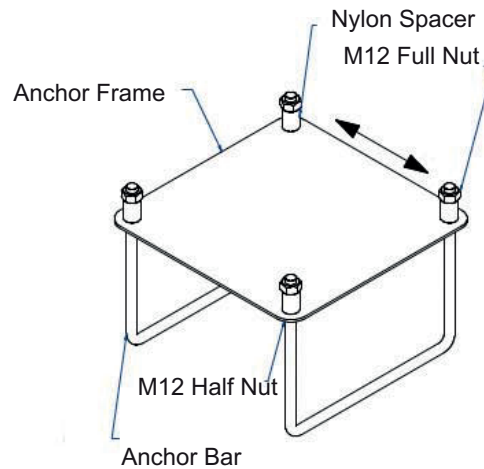
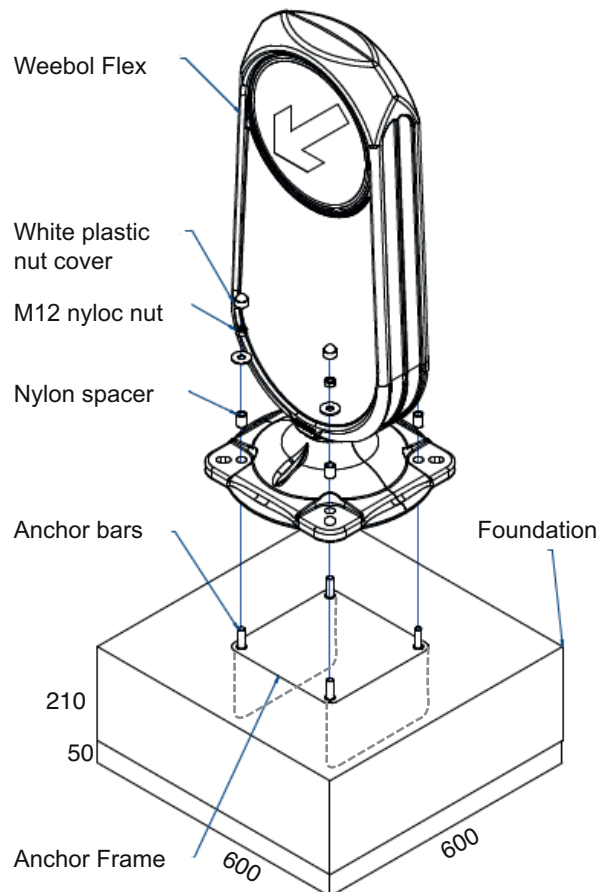

Figure B



Simmons signs Limited reserves the right to alter or improve this guide without prior notice.