

Luminaires not suitable for covering with thermally insulated material



Luminaires not suitable for normally flammable surfaces



SAFETY FIRST

Isolate the mains electrical supply before commencing installation.

All electrical work must be carried out in accordance with the latest IET wiring regulations (BS7671) by suitably qualified engineers.

WARNING: DO NOT STARE AT LEDs

Pack Contents	Nominal Weight	Dimensions	Packaging
LED Array Moulded bracket Array Replacement Label	2kg	595 x 112 x 64mm	1 per box

TOOLS REQUIRED

Tri-head Key – Standard 8mm

Pozidriv recess No. 4 screwdriver

3mm flat terminal screwdriver (Optional)

Optional items	
Stippled lens (to replace existing anti-graffiti panel)	595 x 180 x 3mm
Wiring Shield	630 x 150 x 3mm

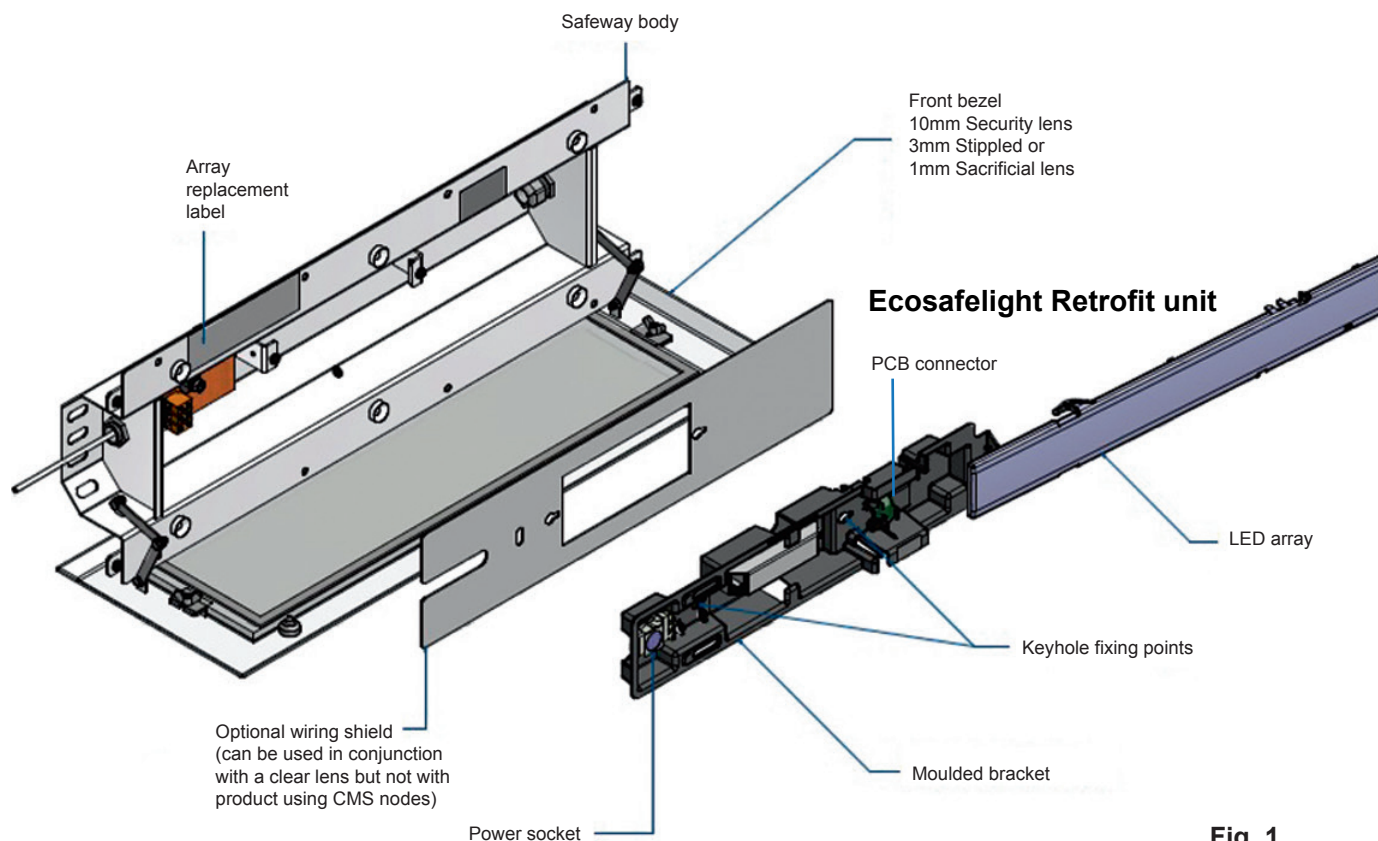

Fig. 1

Simmons signs Limited reserves the right to alter or improve this guide without prior notice.

This guide assumes that the Safeway body is already installed and electrically connected. An additional guide is available which details Safeway installation should this be required.

Method

Isolate power for safe working and removing existing light unit.

1. Undo the six off M8 Tri-head screws, which holds the front cover of the Safeway in place, taking care to support the front bezel whilst lowering it on its hinges.
2. With the front bezel suspended you now have access to the existing light unit.
3. Loosen the two M8 Pozidriv screws with the screwdriver, and slide the existing light unit to the right lifting it off the keyhole slots.
4. Remove the power connector and dispose of the existing light unit in accordance with the current WEEE directive.

Fitting new light unit.

Note: If the finished unit is to retain its existing clear lens, an optional wiring shield can be fitted over the loosened Pozidriv screws, using the keyholes to locate over the two screws before the LED light unit is fitted.

5. Fit the moulded bracket keyholes over the loosened Pozidriv

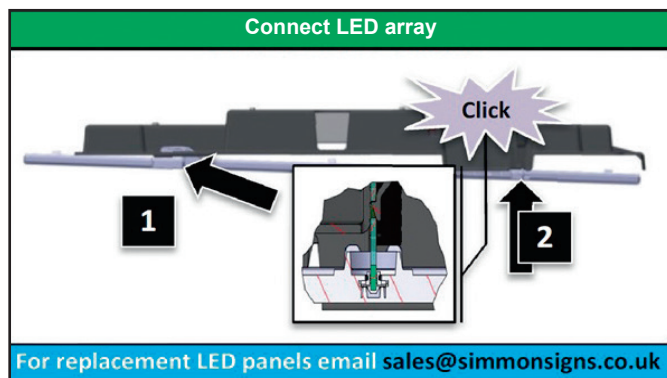

Lighting level adjustment

The switch position is factory set and should not be adjusted on site, this information is provided as a reference for potential future upgrades. Modifying the adjustment will affect the lighting levels prescribed in any lighting design provided.

The lighting level of this unit can be adjusted using the rotary switch as shown in the diagram below. Increments indicate the output level.

A 3mm flat terminal screwdriver may assist in turning.

Switch Position	Power
0	100%
1	10%
2	27%
3	39%
4	47%
5	56%
6	68%
7	82%

screws. **It is essential to check that nothing interferes with any of the equipment fitted to the bracket. In particular if remote monitoring nodes are fitted please ensure they do not rest on top of the incoming supply cable. If this is the case, re-route the supply cable around the perimeter of the housing. Failure to do this is likely to result in damage to the LED array when fitted.**

6. Slide the moulded bracket to the left and re-tighten the Pozidriv screws with the screwdriver. (2Nm)
7. Once the moulded bracket has been secured to the Safeway body, fit the connector plug to the socket.
8. Attach the LED array to the moulded bracket by engaging the two hooks (1) and sliding the LED array fully to the left, keeping the right hand side of the LED array slightly away from the bracket. Ensure that the PCB connector is correctly aligned by checking that you can see this through the LED array mid-way between the clips. The right hand side of the LED array can then be pushed against the clips (2) until it clicks in place.

Fitting the optional stippled lens (If this is not required, please move on to point 11)

9. Loosen the two wing nuts that hold the lenses (the sacrificial and 10mm thick security lens) inside the front bezel and move the plates aside to release the lenses.
10. Remove the sacrificial lens and replace it with the stippled lens (stippled side against the 10mm thick lens). Reposition the lenses (the stippled and 10mm thick security lens) and re-tighten the wing nuts.
11. The array replacement label should be fixed to the inside front face of the Safeway body as shown in the diagram (Fig1). This is for future reference.
12. Lift and reposition the front bezel and fix into place with the retained six off M8 Tri-head screws.

Disconnecting LED array

To disconnect the LED array from the moulded bracket, simply apply a gentle squeezing force with thumb and index finger on each of the two clip heads shown (1) and pull forward. When released slide the LED panel to the right to disengage the two hooks shown (2).

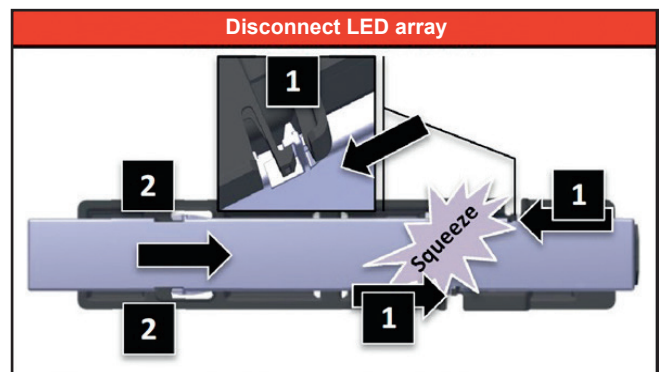

Simmons signs Limited reserves the right to alter or improve this guide without prior notice.