

### SAFETY FIRST

Isolate the mains electrical supply before commencing installation.

All electrical work must be carried out in accordance with the latest IET wiring regulations (BS7671) by suitably qualified engineers.

Ensure the voltage of the signlight is compatible with the mains supply input. 24 volt versions will require a transformer to reduce mains voltage to the appropriate level.

### TOOLS REQUIRED

LUA bracket of choice (see drawing 1 for options)

M4 Allen key

13mm socket spanner

3mm spade end screwdriver

Philips screwdriver

Tri-head key

Earth Pack (supplied) containing:

- 3 way socket c/w cable clamp and cover
- 1 No. 6mm<sup>2</sup> flexible earth cable c/w 8mm ring terminal and spade terminal
- M8 H/T socket set screw
- M8 S/S nut and washer

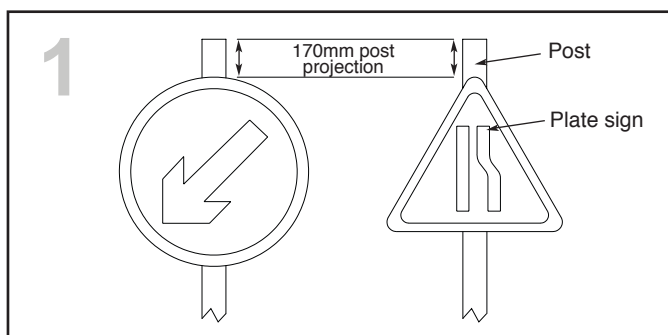

Secure the sign plate to the post.

**Note:** The post should project above the sign plate by 170mm to ensure the required lighting levels are achieved.

Bracket types available: Post top, Through bracket, Two band channel, Wall mounting plate, Clips and Keeps (Note: a Uniplate will be required).

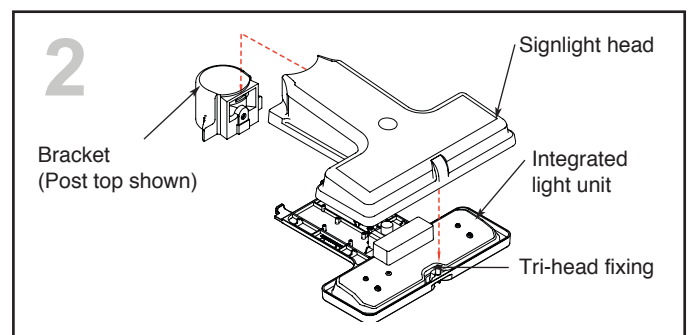

Remove the integrated gear tray by releasing the Tri-head fixing and hinge down gently before unhooking the tangs at the base. Be aware of any additional equipment that may be attached to the LUA body which will need disconnecting before the gear tray can be removed. Additional equipment will typically be remote monitoring nodes and certain photocells.

Dovetail the signlight head onto the bracket.

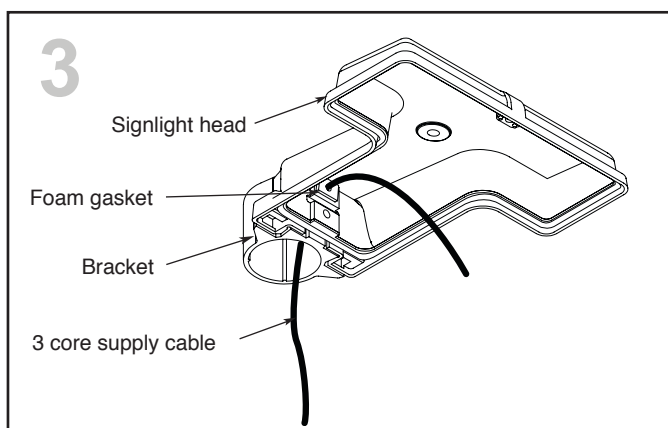

Feed the 3 core supply cable through the slot inside the bracket and on through the hole in the foam gasket at the back of the signlight head.

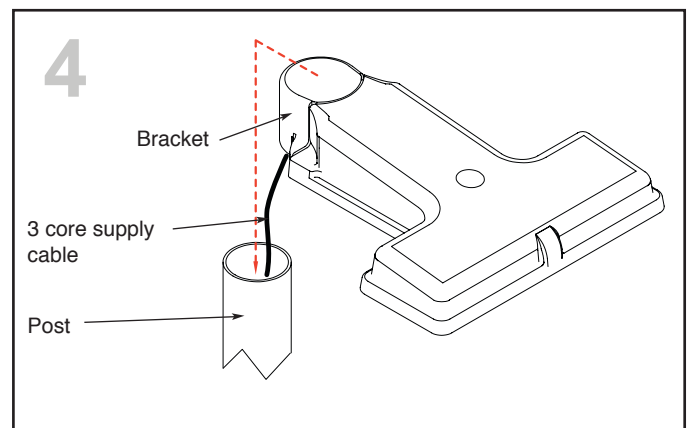

Feed the 3 core supply cable down into the post.

Being careful not to trap the cable, place the bracket onto the post ensuring correct orientation.

Simmons signs Limited reserves the right to alter or improve this guide without prior notice.

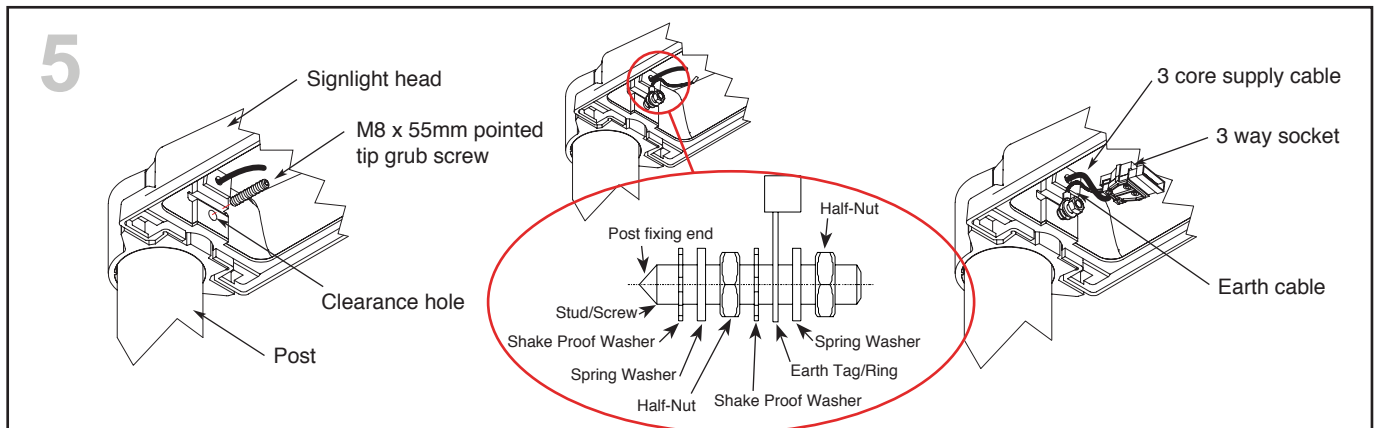

Take the M8 x 55 mm pointed tip grub screw and pass it through the clearance hole in the sign light head before turning it into the thread in the bracket. Using a 4mm Allen key tighten the grub screw sufficiently to prevent bracket rotation.

**Note: In the following points the earth cable is not required when installing a 24V signlight.**

Having tightened the grub screw, assemble the earth pin in the following sequence:

1. M8 Shake Proof Washer
2. M8 Spring Washer

3. M8 Half Nut – Tighten
4. M8 Shake Proof Washer
5. 6mm<sup>2</sup> Earth wire – 8mm ring tag.
6. M8 Spring Washer
7. M8 Half Nut – Tighten

Strip the live, neutral and earth ends on the supply cable and connect with the terminals marked L.N.E. on the 3-way socket. Note: The spade terminal from the earth cable should be wired into the same terminal as the earth end of the supply cable.

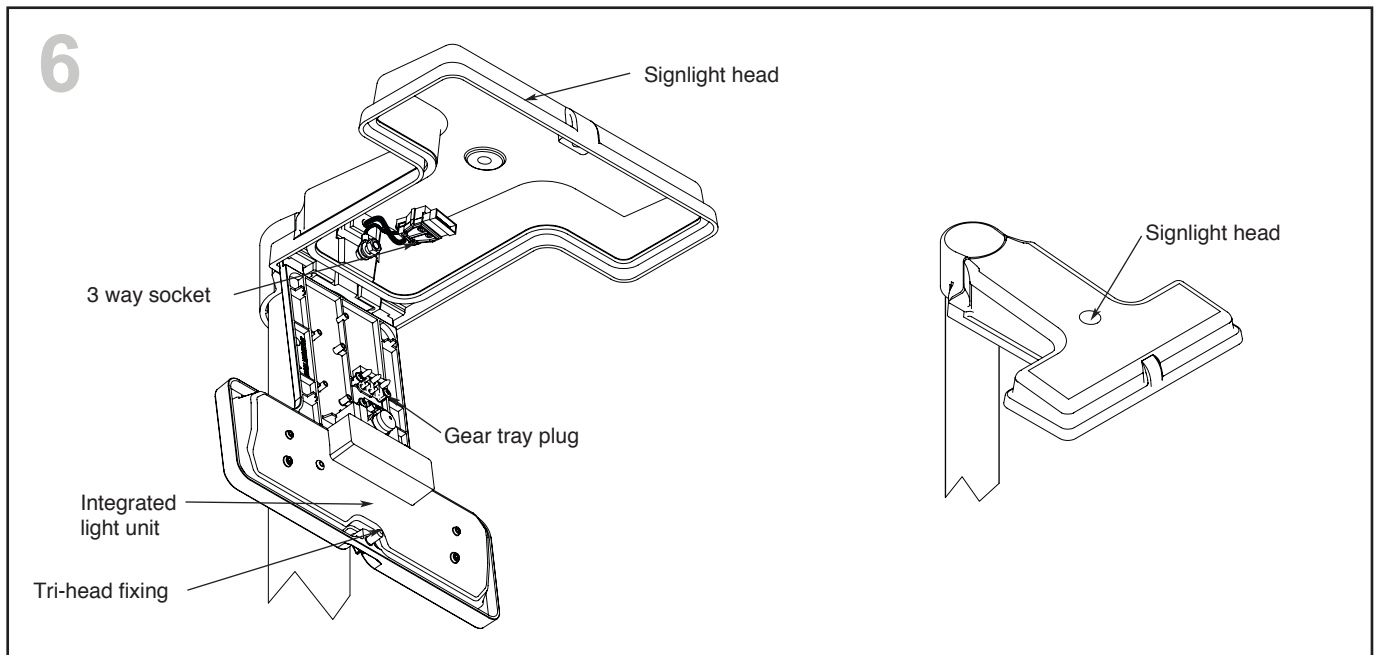

Use the tangs at the back of the integrated light unit to connect it back onto the signlight head.

Before fully closing the integrated light unit, connect the free end of the 3 way socket onto the gear tray plug.

Make a final visual check of the gear tray to ensure that any photocell has not moved during transport and continues to line up with the PEC window, then hinge up the integrated light unit and secure with the Tri-head fixing. **Note:** Do not over tighten.

**Finally:** Reconnect the mains supply and check the signlight is working.

Simmons signs Limited reserves the right to alter or improve this guide without prior notice.