

GLOBAL INSTALLATION

Safety First - Ensure that the site is surveyed for buried services and that the electrical supply is isolated before commencing work.

Excavation

1. Into firm ground and with a floated concrete finish, excavate a hole 600mm square at least 155mm deep. (Diagram 2)

OR

1. Into unsound substrate or where a bituminous or block pavior finish is required, excavate a hole as above plus a further central 450mm square 150mm deep. N.B. The concrete mix should finish no less than 305mm from ground level and include 4 no. M10 J bolts protruding 30mm minimum, on 355mm centres to match the Global anchor flange. When set remove the 4 no. M10 CSK set screws from this flange, check for correct base orientation, sit the base over the protruding bolts, apply and tighten nuts and washers. (Diagram 3)

Installation

1. Loosen the Tri-head fixing and open the Global Hinge Frame. Remove and retain the domed lens and light unit.
2. Run cables into the Global via the chosen sealing option and terminate / earth bond in accordance with IEEE wiring regulations into a suitable cut-out.

Note: Ensure that the cable is looped to prevent sideward pressure on the glands and that gland nuts are fully tightened or, alternatively sub seals are installed strictly in accordance to the Global Subseal installation instructions.

3. Remove the power lead from the Global light unit or DPI switch lead (if supplied) and wire into the cut-out.
4. Replace the domed lens, cover the hinge frame with the clear plastic bag provided and close. Secure the hinge frame with the Tri-head fixing.

Equipment required

Tri-head key
13mm spanner
Specified cut out & foundation
C20 grade concrete or equivalent.

5. Place the Global into the hole and pack the underside of the casting to ensure that it is horizontal and that the underside of the webbed platform is at ground level.

6. Fill the foundation around the Global with C20 grade concrete up to ground level to the underside of the webbed platform. (Diagram 4)

Note: Ensure that no concrete or tarmac is present beneath the hinge frame or around the hinge as this would prevent it from opening or closing fully.

7. Loosen the Tri-head fixing and open the Global Hinge Frame. Remove and retain the domed lens.

8. Plug the power lead into the Global Light Unit. Place the light unit into the Global - ensuring correct orientation.

9. Remove the clear plastic bag from the hinge frame and replace the domed lens ensuring correct orientation.

10. Place the Symbol or Contour onto the hinge frame and secure.

Note: Ensure correct orientation of the bollard diagrams and secure. Use M8 stainless nuts, bolts and washers for a flexible bollard (IR3 TTB) or nylon drive pins for a rigid bollard (IR1 TTB).

11. Close the hinge frame and secure using the Tri-head fixing.

Note: Once secure there should not be a gap between the hinge frame and the webbed platform.

12. Reconnect power supply and test.

Note: Failure to follow these instructions may result in premature failure of the product.

Simmons signs Limited reserves the right to alter or improve this guide without prior notice.

Cable options - maximum diameter

Standard Glands and Twin turret with glands:
9mm - 14mm or 13mm - 18mm outside diameter cable.

Twin turret no glands and Subseal:
20mm maximum outside diameter.

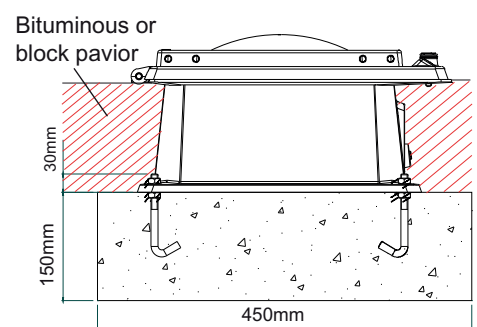
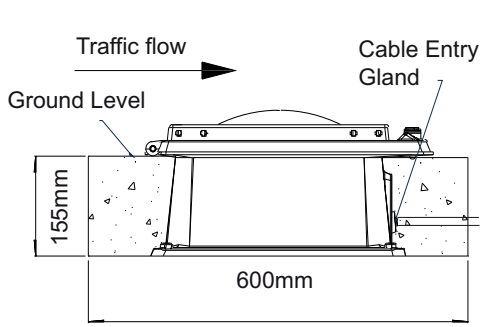
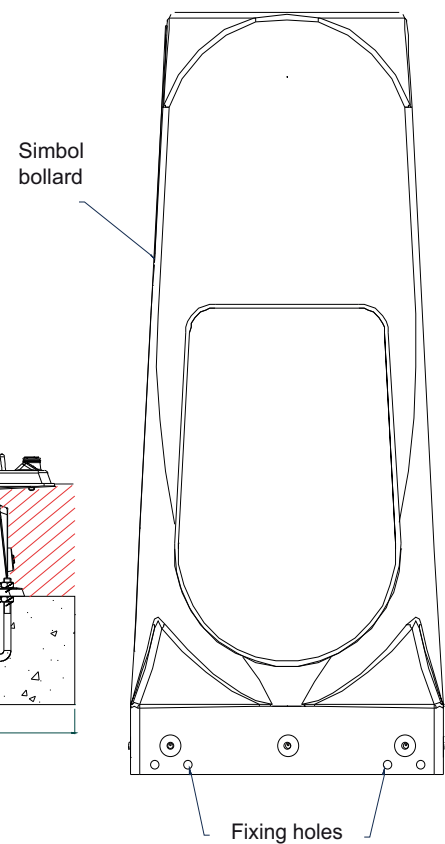
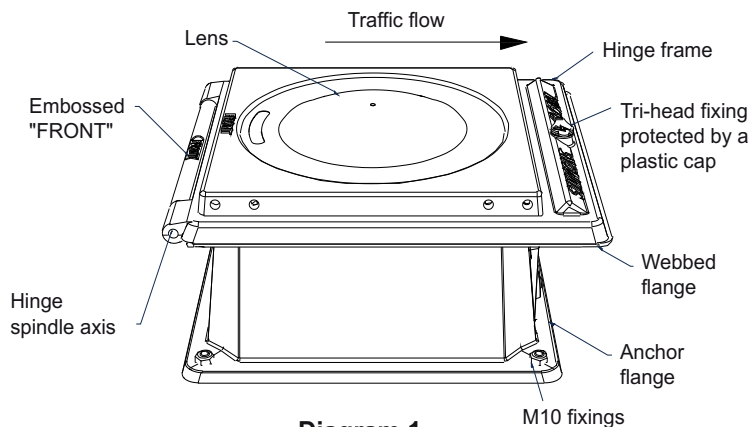

Diagram 2

Diagram 3

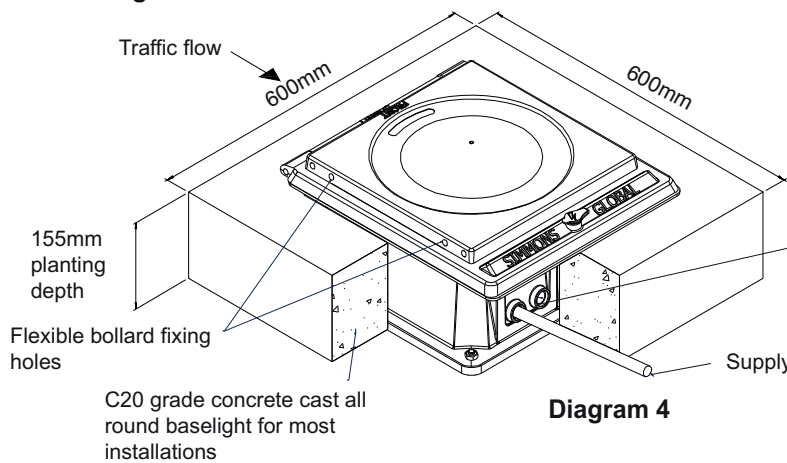

Diagram 4

Spare gland must be sealed if not used
Note: Ensure cable glands are fully tightened onto supply and loop cables. Factory fitted blanking plate supplied as standard

Supply cable should be clean to aid gland seal

Simmons signs Limited reserves the right to alter or improve this guide without prior notice.